

A

B

C

D

REVISIONS

ZONE	REV.	DESCRIPTION	DATE	APPD.

1

2

3

4

5

6

7

8

9

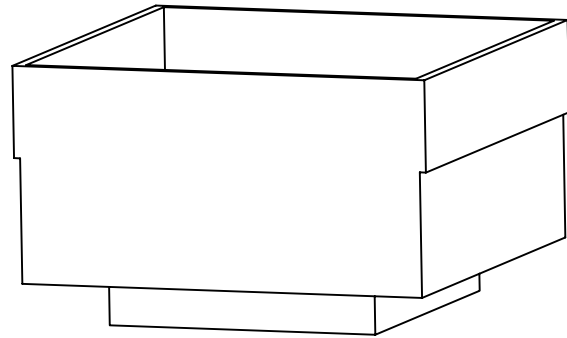
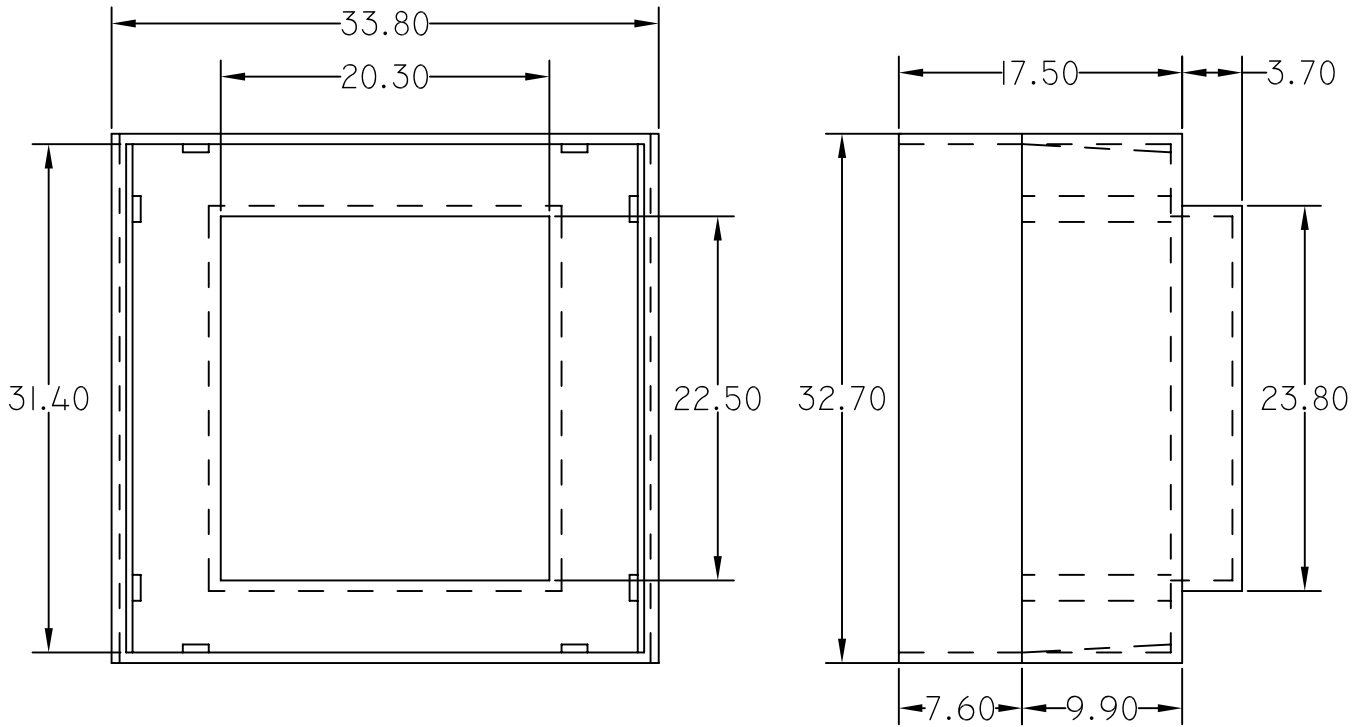

COMPONENT WEIGHT - 4.2 GMS

NOTE:

- (1) All dimensions are in mm.
- (2) Tolerance for all dimension is (± 0.2)
- (3) Molding Material:
 - (a) Zytel FR 50 BK 153J - UL & RoHS
 - (b) Zytel 70G33L BK 031 - Non UL
 - (c) Zytel 70G33L NC 010 - Non UL
 - (d) Ultramid A3X2G5 - UL & RoHS



DURGA ELECTRONICS (INDIA)

COMPONENT NAME: POTTING SHELL

PART NO: EE 30

REMARKS:

REV.

00

	NAME	SIGN.	DATE
DESIGN BY	SACHIDANAND		16.01.03
CHECKED BY	MANOJ GUPTA		16.01.03
APPR. BY	MANOJ GUPTA		16.01.03

SCALE: NTS	DRG.NO: DEI/DRG/0237	PATH
------------	----------------------	------

D:\DURGA\POTTING SHELL\POTTING SHELL EE30